

# 2600 Series Economy Extinguisher Cabinets

**GUARDIAN**  
FIRE EQUIPMENT, INC.



## Aluminum Cabinets

### Models 2605-2625

- Accommodate: Fire Extinguishers - refer to size chart

### Standard Construction & Features

- Corrosion-resistant lightweight aluminum construction
- Full single strength break glass panel
- Red decal lettered "Break Glass for Fire Extinguisher"
- Stainless steel tamper-proof screws
- Aluminum hammer with cable attachment
- Surface mount design

### Options

- Add suffix **-CL** to cabinet model no. for cylinder lock
- Add suffix **-PH** to cabinet model no. for center pull handle and breakaway plexiglass panel (no hammer)

Model No.	Dimensions			Accommodate Guardian Extinguishers
	Width A	Height B	Depth (Inside) C	
<b>White</b>				
<b>2605</b>	8 1/2"	19 13/16"	6 1/4"	<b>Dry Chemical: 5 lb.</b>
<b>2615</b>	9 1/2"	25 3/4"	6 1/4"	<b>Dry Chemical: 5, 6, or 10 lb.</b>
<b>2625</b>	10 1/2"	29 3/4"	8 1/4"	<b>All Dry Chemical; Water/Foam: 2.5 gallon</b>



2605-2625

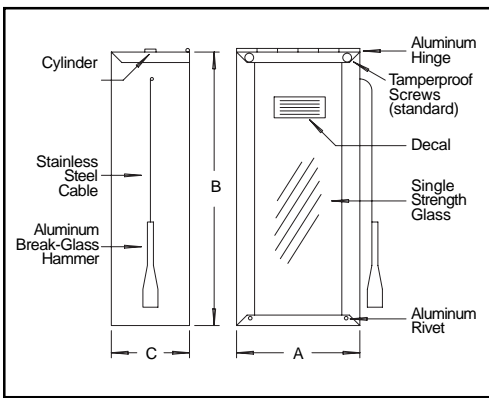

## Plastic Cabinets

### Models 2655-2670

- Accommodate: Fire Extinguishers - refer to size chart

### Standard Construction & Features

- Injection molded ABS plastic construction
- Full clear pull cover with break tab and brass lock
- White decal lettered, "Pull Here - Only in case of Fire"
- Surface mount design

### Options

- Add suffix **-RC** to cabinet model no. for red pull cover - recommended for outdoor use

Model No.		Dimensions			Accommodate Guardian Extinguishers
White	Red	Width A	Height B	Depth C	
<b>2655</b>	<b>2660</b>	8 1/2"	18 7/8"	6 1/2"	<b>Dry Chemical: 5 lb.</b>
<b>2665</b>	<b>2670</b>	9 3/4"	25"	6 1/4"	<b>Dry Chemical: 5, 6, or 10 lb.</b>



2655-2670

